

VICKERS®

Directional Controls



Solenoid Operated Directional Control Valves

NFPA D05, ISO-4401-05

DG4S*-01**-5* Air Gap Type

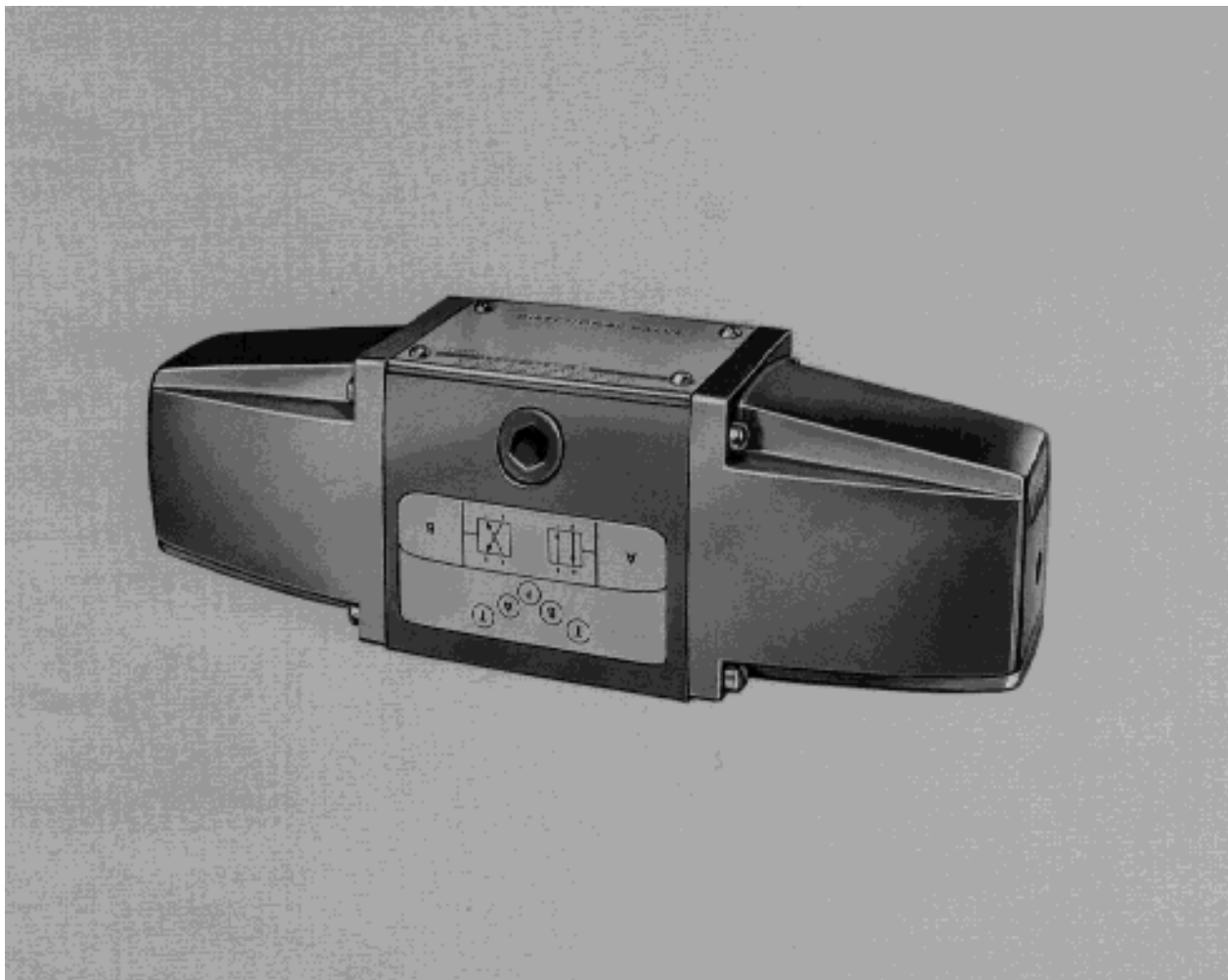

VICKERS

Revised 8/97

Table of Contents

- DG4S*-01 Model Code 3
- General Information 4
 - Basic Characteristics
 - Mounting Position
 - Installation Data
 - Service Information
- Spool Type & Graphical Symbols 5
- Pressure Drop 6
- Flow Ratings 7
 - Port Orifices
- Installation Dimensions 8
- Subplates & Bolt Kits 11
- Electrical Information 12
- Electrical Connectors 14
- Application Data 16

Introduction

DG4S*-01 models are air gap type, direct solenoid operated, 2-way or 4-way directional control valves. Their primary function in a hydraulic circuit is to direct fluid flow to a work cylinder or

to control the direction of rotation of a hydraulic motor.

Port connections are made by mounting the valve on a manifold or subplate containing the interface.

Valves are available with AC or DC solenoid(s). Electrical connections to the valve are made in an electrical wiring terminal box or by various plug-in devices. A ground terminal is provided.

Model Code

Two & Four-way Directional Valves

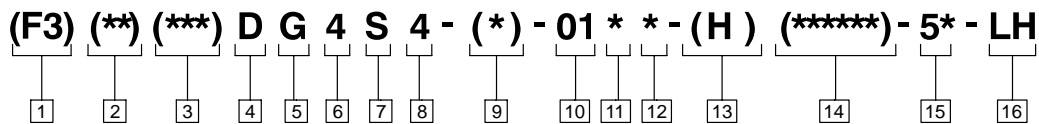

1 Special seals

- Blank** - For petroleum oils, water glycols and invert emulsions
- F3** - Mineral oil & fire resistant fluids

2 Optional features

- S** - Monitor switch for spring offset (A and F models only)
- X** - Solenoids for hazardous locations
- XM** - Solenoids for mining applications
NOTE: X or XM not available with plug-in options monitor switch or indicator lights.
- Blank** - Omit if not required

3 Electrical plug-in options

- PA** - Insta-plug (male receptacle)
- PB** - Insta-plug (male & female receptacle)
- PA3** - NFPA 3-pin connector
- PA5** - NFPA 5-pin connector
- Blank** - Omit if not required

4 Control type

- D** - Directional valve

5 Mounting type

- G** - Manifold or subplate

6 Operation

- 4** - Solenoid operated

7 Valve type

- S** - Sliding spool

8 Flow direction

- 2** - Two-way flow direction
- 4** - Four-way flow direction

9 Electrical accessories

- L** - Solenoid indicator lights (for use with 100 through 125 and 192 through 233 voltage service only). Not available for hazardous duty units.
- W** - Wiring housing
- Blank** - Omit if not required

10 Valve size

- 01** - NFPA-D05 (ISO-4401-05) Interface

11 Spool type

- 0** - Open center all ports
- 1** - Open center P & A, closed B
- 2** - Closed center all ports
- 3** - Closed center P & B
- 6** - Closed center P only
- 7** - Open center, T blocked
- 8** - Tandem open crossover

12 Spool/Spring arrangement

- A** - Spring offset
- B** - Spring center, two position
- C** - Spring centered, three position
- F** - Spring offset, energize to center
- N** - No spring, detented

13 Solenoid (air gap)

- H** - Oil immersed (optional)
- Blank** - Omit if not required

14 Electrical service

- Blank** - Standard 115V AC 60 Hz
- *** - Specify other voltages and frequencies, including 230V AC 60 Hz, 24V DC etc.

15 Design number

Subject to change. Installation dimensions remain as shown for designs 50 through 59

16 Spring offset models

- LH** - Left hand assembly, solenoid A. Omit for right hand assembly
For spool/spring arrangements A, B, & F only (energizing solenoid B provides flow from P to A)

General Information

Basic Characteristics

Max. pressure: 207 bar (3000 psi)
P, A, & B ports.
Max. flow: 75,7 l/min (20 USgpm)
Weights:
Single solenoid 4,1 kg (9 lbs)
Single solenoid, plug-in type
..... 4,5 kg (10 lbs)
Double solenoid 4,6 kg (10.3 lbs)
Double solenoid, plug-in type
..... 5,1 kg (11.3 lbs)
Fluid Cleanliness: See page 15.

Mounting Interface

ISO 4401-05
CETOP 5
NFPA D05

Mounting Position

No-spring detented valves must be installed with the longitudinal axis horizontal for good machine reliability. The mounting position of spring-offset and spring-centered models is unrestricted.

Installation Data

On two-way valves, "T" drain connection must be piped directly to tank through a surge free line so there will be no back pressure at this port.

NOTE

Any sliding spool valve, if held for long periods of time, may stick and not spring return due to fluid residue formation and therefore, should be cycled periodically to prevent this from happening.

Service Information

Refer to specific Vickers parts drawing for service parts information. A complete parts breakdown is contained in this drawing.

Order by literature number.

Electrical Accessories I-3465-S
Insta-Plug Connector I-3487-S
DG4S*(L)-01*N-(**AC*)-5* I-3471-S
DG4S4-01*(*)C-(*)-5* I-3477-S
DG4S2-012C-(*)-5* I-3477-S
DG4S2(L)-012A-(*AC*)-5* . I-3478-S
DG4S4(L)-01*A-(*AC*)-5* . I-3478-S
DG4S4(L)-01*C-H-(*AC*)-5* I-3483-S
DG4S*(L)-01*A-H-(*AC*)-5* I-3485-S
SDG4S*(L)-01*A-5* I-3489-S
DG4S4-01*C-*DC-5* I-3506-S
DG4S2-012A-*DC-5* I-3507-S
DG4S4-01*A-*DC-5* I-3507-S
XDG4S2-012N(*AC*)-5*-* . I-3523-S
XDG4S4-01*N(*AC*)-5*-* . I-3523-S
XDG4S2-012A(*AC*)-5* . . . I-3527-S
XDG4S4-01*A(*AC*)-5* . . . I-3527-S

Functional Symbols

No-Spring Detented "N"

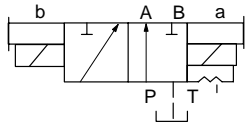

Two-way valve

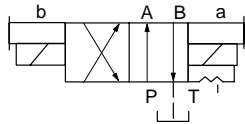

Four-way valve

Energize to Center "F"

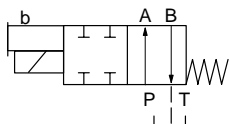

Four-way valve

Spring Centered "C"

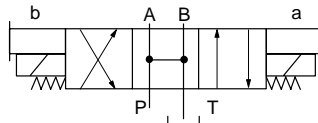

Four-way valve

Spring Offset "A"

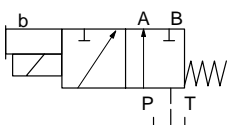

Two-way valve

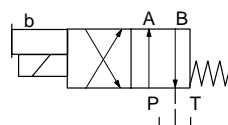

Four-way valve

Spring Offset "B"

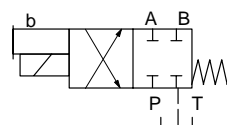

Four-way valve

Spool Type & Graphical Symbols ▾

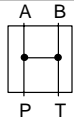
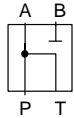
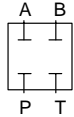
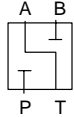
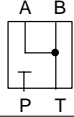
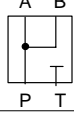
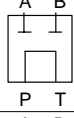
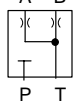







Model Number				Standard Spool Types	
Spring Centered -B&C-	Spring Offset -A-	No-Spring Detented	Energize to Center -F-	Center Position & Spool Type	Description
DG4S4*-010C-5*	DG4S4*-010A-5*	DG4S4*-010N-5*	DG4S4*-010F-5*	"0" 	Open center all ports
DG4S4*-011C-5*				"1" 	Open center P & A
DG4S4*-012C-5*	DG4S4*-012A-5*	DG4S4*-012N-5*	DG4S4*-012F-5*	"2" 	Closed center all ports
DG4S4*-013C-5*			DG4S4*-013F-5*	"3" 	Closed center P & B
DG4S4*-016C-5*	DG4S4*-016A-5*	DG4S4*-016N-5*	DG4S4*-016F-5*	"6" 	Closed center P only
DG4S4*-017C-5*		DG4S4*-017N-5*	DG4S4*-017F-5*	"7" 	Closed center T blocked
DG4S4*-018C-5*				"8" 	Tandem P to T open crossover
DG4S4*-0133C-5*		DG4S4*-0133N-5*		"33" 	Closed center bleed A & B

▼ See Pressure Drop table on next page.

→ Full flow

→ Restricted flow

Pressure Drop

Spool Type & Center Position	Description	Pressure Drop bar (psi) @ 37,9 l/min (10 USgpm)					Maximum Tank Line Back Pressure bar (psi)
		P → A	B → T	P → B	A → T	P → T on Center	
"0" 	Open center all ports	1,93 (28)	1,65 (24)	1,93 (28)	2,28 (33)	2,28 (33)	At time spool shift is required - 68 (1000) At time spool shift is NOT required 207 (3000)
"1" 	Open center P & A	2,14 (31)	2,41 (35)	2,14 (31)	2,56 (37)		
"2" 	Closed center all ports	2,14 (31)	2,41 (35)	2,14 (31)	2,76 (40)		
"3" 	Closed center P & B	2,14 (31)	2,41 (35)	2,14 (31)	2,28 (33)		
"6" 	Closed center P only	2,14 (31)	1,65 (24)	2,14 (31)	2,28 (33)		
"7" 	Closed center T blocked	1,93 (28)	2,28 (33)	1,93 (28)	2,76 (40)		
"8" 	Tandem P to T Open Crossover	1,45 (21)	1,65 (24)	1,45 (21)	1,93 (28)	4,48 (65)	
"33" 	Closed center bleed A & B	2,14 (31)	2,28 (33)	2,14 (31)	2,76 (40)		
"2" 	Closed center crossover	2,14 (31)	Blocked	2,14 (31)	Blocked	3,45 (50) Drain Do not plug tank port.	

Note

When solenoid "a" is energized, flow is always P→A. When solenoid "b" is energized, flow is always P→B. This is in accordance with the ANSI-B93.9 standard. Standard spring offset valves are assembled right hand, such that flow is P → A in the spring offset position (solenoid is de-energized). Solenoid "a" and "b" are identified on the diagram plate.

1. Pressure drop data gives approximate pressure drop (ΔP) when passing 21 cSt (100 SUS) fluid(s) having .865 specific gravity.
2. For any other viscosity(s), the pressure drop (ΔP) will change as follows:

Viscosity								
cSt	14	32	43	54	65	76	86	
(SUS)	(75)	(150)	(200)	(250)	(300)	(350)	(400)	
% of ΔP (Approx.)	93	111	119	126	132	137	141	

3. For any other specific gravity (G_1)*, the pressure drop (ΔP_1), will be approximately:

$$\Delta P_1 = \Delta P(G_1/G)$$

* Specific gravity of fluid may be obtained from its producer. The value is higher for fire-resistant fluids than for oil.

Flow Ratings

Valve Type	Spool Type	Recommended Flow Capacity	Maximum Flow without Malfunction ▪
No Spring Detented 4-way	0, 2, 6, 7, 33	38 l/min (10 USgpm)	76 l/min (20 USgpm)
Spring Centered	0, 2, 3, 6, 7, 33		
Spring Offset 4-way	0, 2, 6		
Spring Centered	8	30,3 l/min (8 USgpm)	45,5 l/min (12 USgpm)
Spring Centered	1	18,8 l/min (5 USgpm)	18,8 l/min (5 USgpm)
No-Spring Detented 2-way	2	11,3 l/min (3 USgpm)	11,3 l/min (3 USgpm)
Spring Offset 2-way			

▪ Maximum flow is dependent upon the valve type used and is subject to variation due to changes in operating pressure or tank line back pressure. If operating pressure and tank line back pressure simultaneously approach maximum, or if higher flow rates are desired, contact your local distributor or a Vickers representative.

Port Orifices DG4S4-01 Interface

Orifices are available for insertion into the interface ports of the NFPA-D02 size valves. These orifices are made from standard $1/16$ " NPT pipe plugs which are inserted into a retainer. The retainer and plugs are available from stock as follows:

- 222500 Retainer
- 62014 \varnothing 7,9 (.031) plug
- 66609 \varnothing 1,02 (.040) plug
- 237588 \varnothing 1,5 (.060) plug
- 82031 \varnothing 2,4 (.094) plug
- 81593 Blank plug

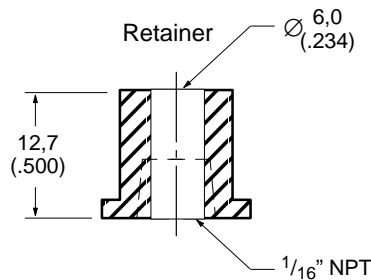

Installation Dimensions

Double Solenoid, No-spring Detented & Spring Centered Models

Millimeters (inches)

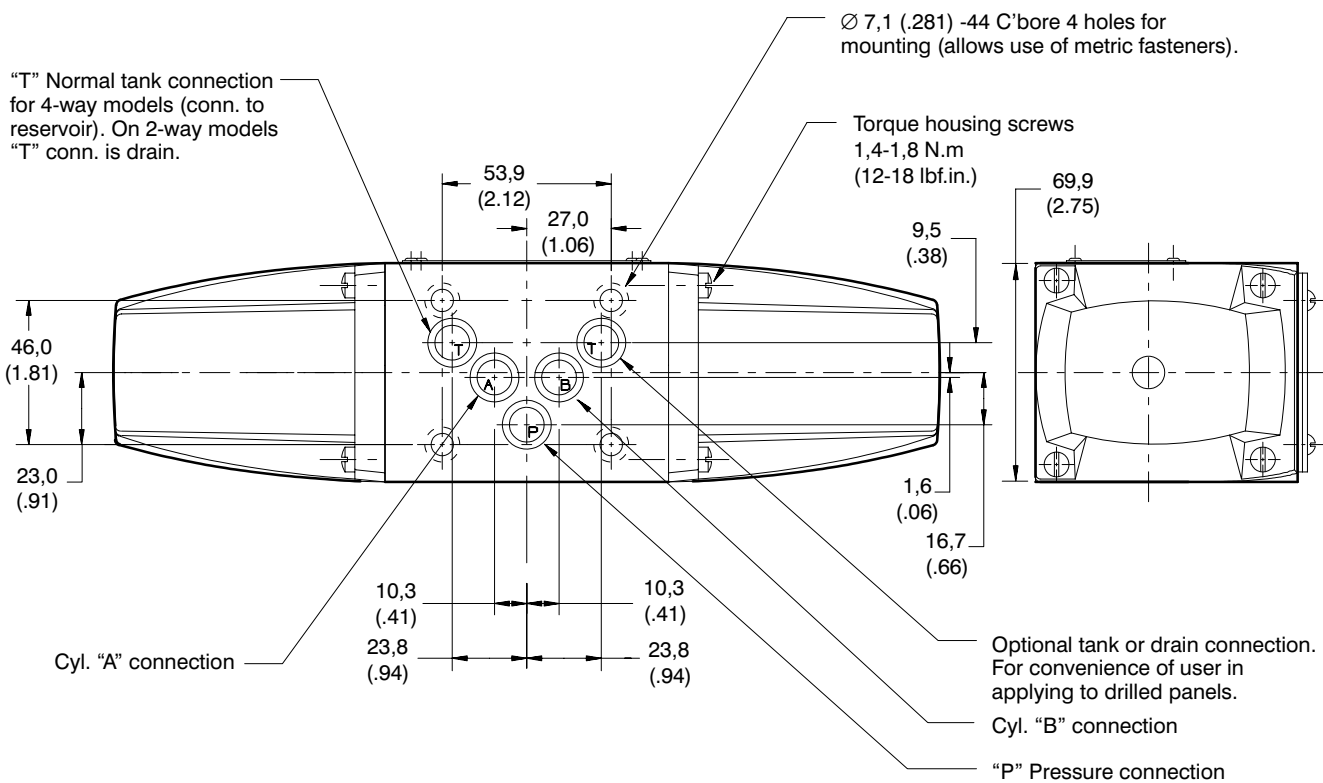
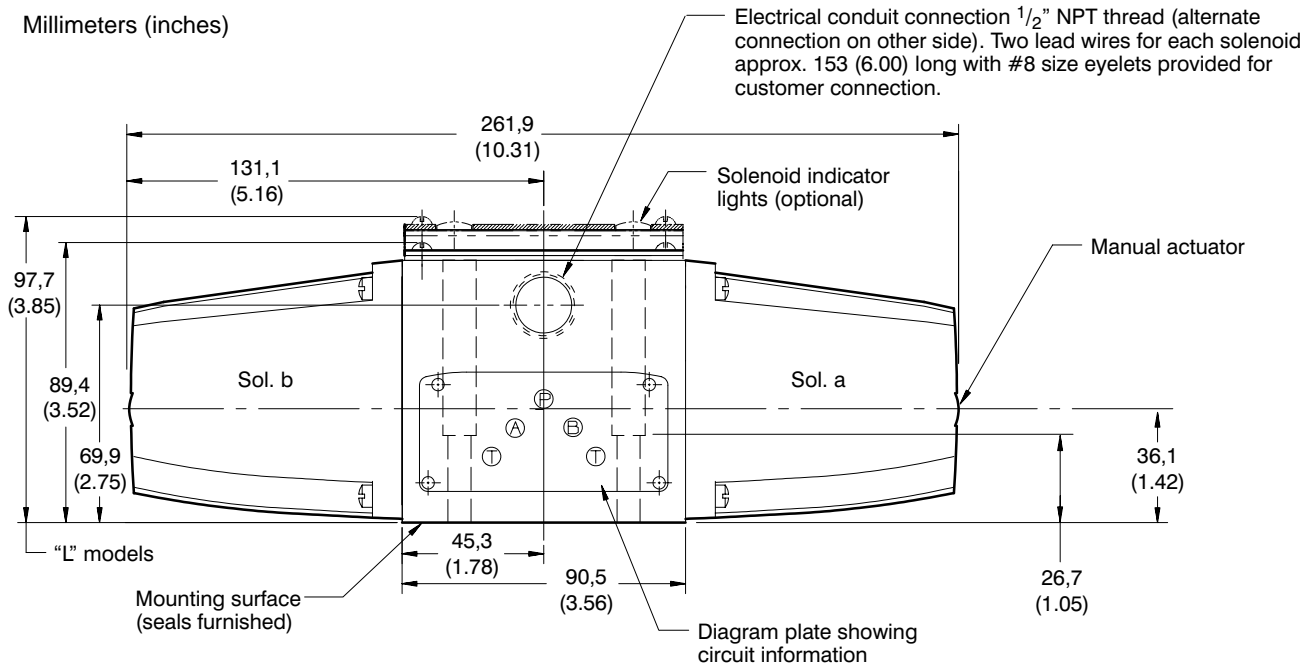

Single Solenoid with Monitor Switch

Millimeters (inches)

An integral monitor switch permits electrical interlocking of various hydraulically controlled motions without resorting to external mechanical contrivances. The switch monitors the valve spool position and may be wired into the control circuit.

Volts	AC amp	DC amp
28	20	10
125	20	0.5
250	20	0.2
480	20	
600	5	

Monitor switch housing does not provide for manual operation.

Monitor switch data:

Plunger type

- panel mounting
- single pole
- double throw contact arrangement
- "A" normally closed
- "B" normally open

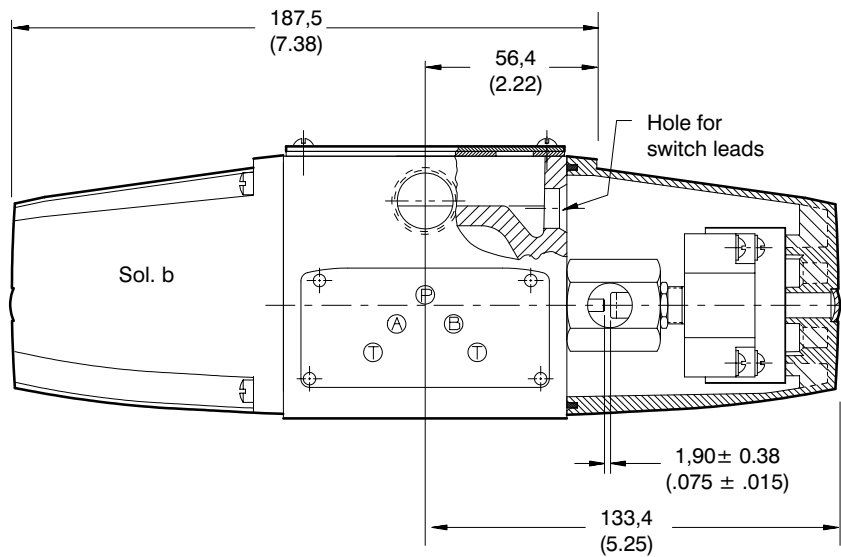

Subplates & Bolt Kits

Valves, subplates and mounting bolts must be ordered separately.

Example:

- One (1) DG4S4-012A-50 Valve
- One (1) DGSM-01-20-T8 Subplate
- One (1) BKDG01-633 Bolt Kit

When subplate is not used, a machined pad (as indicated by subplate shaded area, below) must be provided for mounting. Pad must be flat within 0,0127 mm (.0005 inch) and smooth within 63 microinch. Mounting bolts, when provided by customer, should be SAE grade 7 or better.

Side connection subplates are also available with $\frac{3}{8}$ " and $\frac{1}{2}$ " pipe threads.

Torque mounting bolts to:
13 Nm (115 lb. in.)

Mounting Subplates

Millimeters (inches)

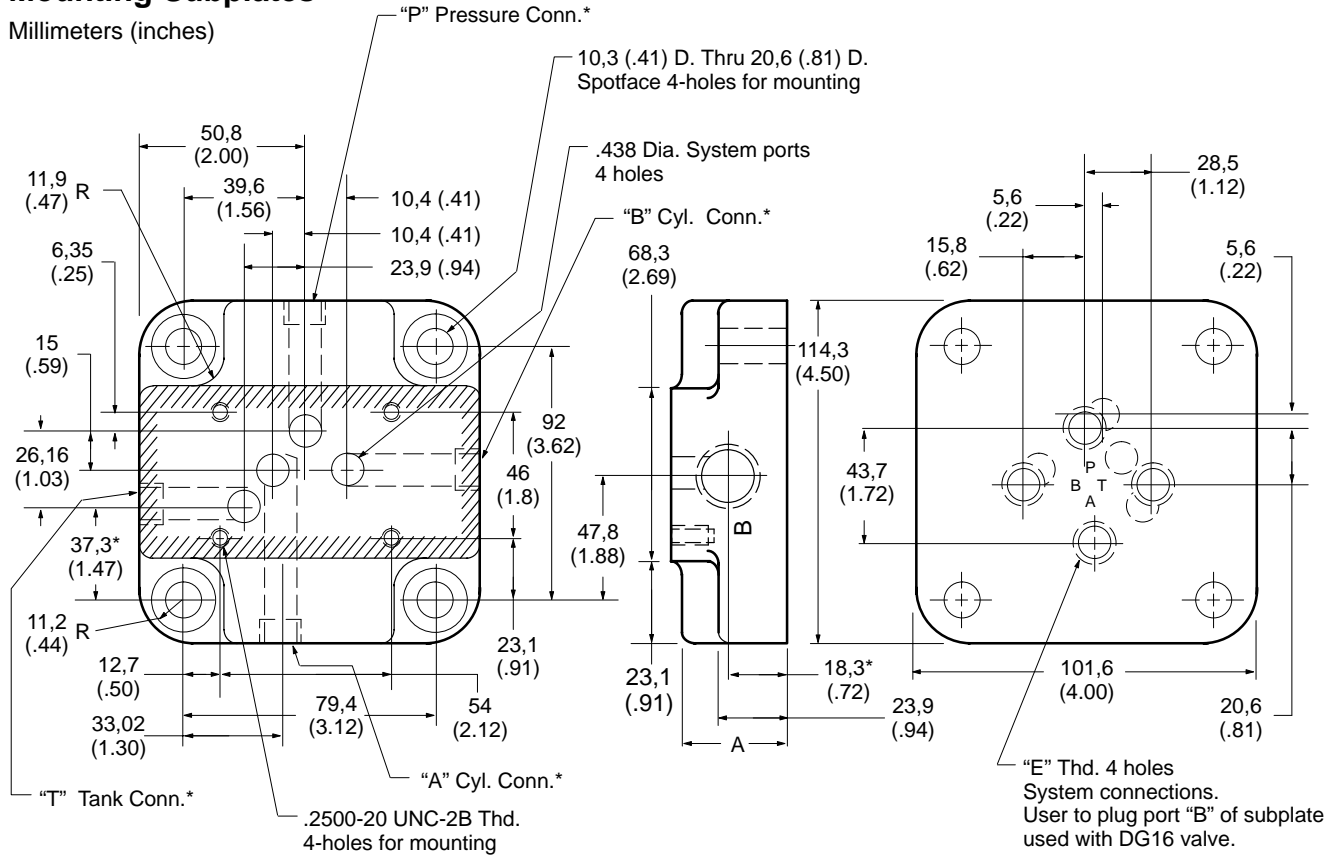

Model Numbers	"E" Thread	Tube Size	Dimension "A"
DGSM-01-20-T8	.750-16 UNF-2B	$\frac{1}{2}$ " O.D.	31,75 (1.25)
DGSME-01-20-T8	.750-16 UNF-2B	$\frac{1}{2}$ " O.D.	38,10 (1.50)

* Ports on Model DGSME-01-20-T8 only.

Electrical Information

Solenoids

Solenoids on models listed are for 115V AC - 60 Hz service. Solenoids for other voltages and frequencies are available. Specify in model number if other than 115V AC - 60 Hz service is desired. See model code for options.

Note

Solenoids are designed to function continuously at $\pm 10\%$ of the rated voltage.

Note

All solenoid coil wire insulation is Class "F". Standard solenoid coil lead wire has Class "A" insulation. "F3" solenoid coil lead wire is Class "F".

Solenoid Energizing

Spring centered and spring offset types will be spring positioned unless solenoid is energized continuously. No-spring detented valves may be energized momentarily, approximately 0.1 second; when solenoid is de-energized spool will remain in last position attained provided there is no shock, vibration, or unusual pressure transients.

Solenoid Current approx. Maximum	Inrush amps	Holding amps	Holding watts
* 115V AC - 60 Hz	5.1	.61	—
* 230V AC - 60 Hz	2.55	.32	—
460V AC - 60 Hz	1.27	.16	—
115V AC - 50/60 Hz	(50) 3.25 - (60) 4.97	(50) .56 - (60) .59	—
6V DC		4.0	24
* 12V DC		2.0	24
* 24V DC		1.0	24

* Canadian Standards Association Certification. Valves with solenoid voltages of 115V AC - 60 Hz, 230V AC - 60, 12V DC and 24V DC have Canadian standards certification. Identify by adding S324 suffix in the model code. This certification does not include models with indicator lights (L) or plug-in devices (PA*/PB).

Electrical Accessories & Options

Wiring Housing - Lights for DG4S*/DG5S4/DF5S4 Valves

The electrical accessories options are available on the basic DG4S*01-* directional control and all valves that use the DG4S4-01* as pilot valve. An electrical wiring diagram is provided on the bottom of the nameplate, and shown below, for installation instructions.

Lights (L)

Lights are "on" when there is voltage across the solenoids. (Only double lights are available.) Lights are available with most options (the light option has an integral terminal strip) and are for use with 100 through 125 and 192 through 233 volt service solenoids only. They are not available for hazardous duty type models.

Wiring Housing (W)

The wiring housing (W) is a 39,6 (1.56) high riser block mounted on top of the pilot valve. A 1/2" NPTF thread connection is provided in one end of the housing. The housing can be rotated 180° if the connection is required on the opposite end. This connection will readily accept common electrical quick disconnect assemblies on the market. The wiring housing is available with most options.

Grounding

A drilled hole is provided for a #8 self tapping screw which will permit a ground wire to be secured to the pilot valve body.

Wiring housing "W" has a cast hole 1 (see below) which also permits securing a ground wire with customer's #8 self tapping screw. Units can be series grounded if desired. The DG4S*-01 pilot valve bodies have a cast "ground" symbol adjacent to the drilled hole.

NOTE

Electrical accessories shown are not available with hazardous duty type models identified by model prefix "X" or "XM".

Electrical Diagram

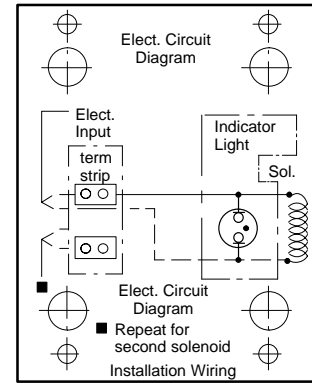

Lights & Wiring Housing W, LW Models

Millimeters (inches)

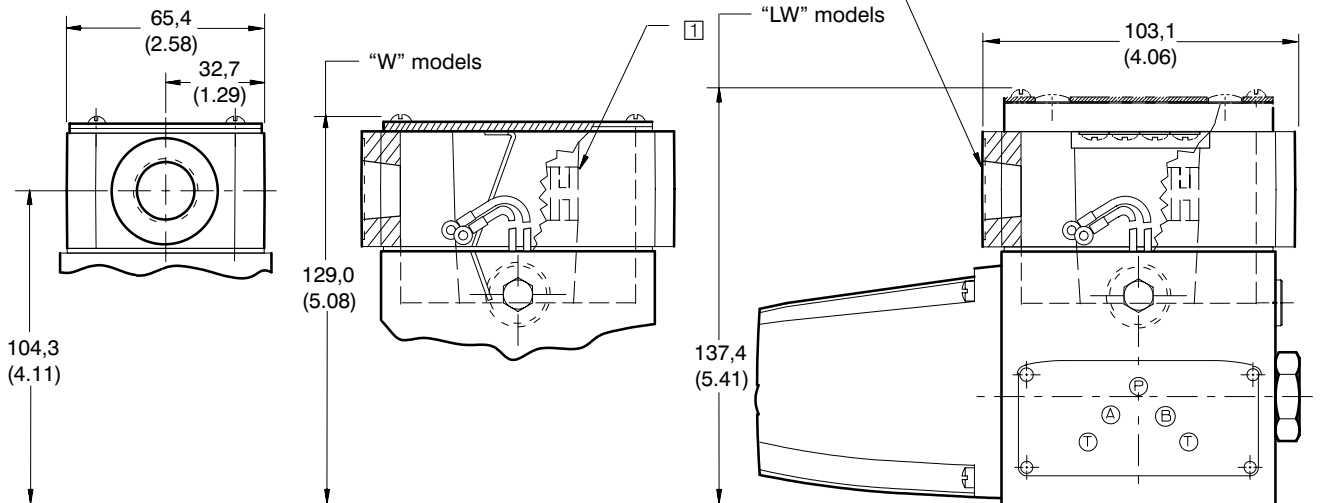

Electrical Connectors

Insta-Plug Option

The insta-plug consists of the following features:

Section "A", a four-pronged self aligning electrical plug secured in a housing that is mounted on top center of the valve body where the solenoid leads terminate; or:

A "B" complete insta-plug assembly that includes the "A" housing on top of which rests a similar housing containing the mating receptacle. The two housings are keyed to assure proper hook-up.

The top housing is removed from the lower ("A") housing to break the

electrical connections to the valve solenoids, or pressed onto the "A" housing to complete the circuit. The assembly is held together by two slotted thumb screws.

A nameplate and solenoid indicator lights are part of the receptacle when specified.

Connections to electric power are made through the end of the receptacle housing and can be pre-wired by the customer. End location of electrical conduit port permits space-saving side-by-side valve mounting.

Wire leads approximately 177.8 mm (7.00") long are provided when no lights

are specified. Models with lights have terminals inside the receptacle housing.

After initial installation, electrical and hydraulic connections need not be disturbed when valve with insta-plug is removed.

NOTE

Solenoids "A" and "B" are identified on the plug-in and receptacle housing; they correspond with solenoid identification plate. In case of tandem valves (#8 spool and LH models), the insta-plug is rotated 180° and conduit connection is on the opposite end.

Lights & Wiring Housing Insta-Plug

Millimeters (inches)

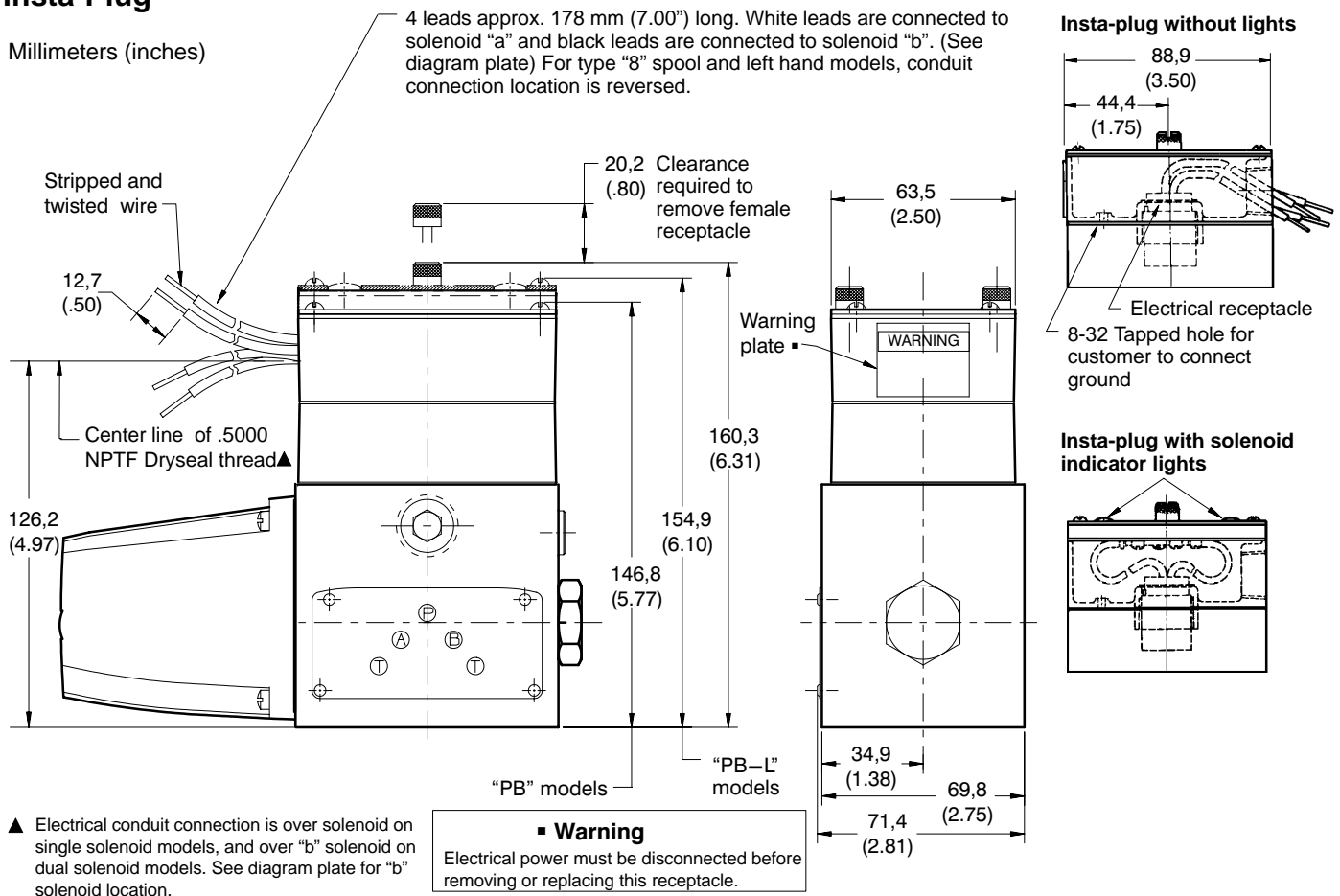

NFPA Hydraulic Valve Electrical Connector

The receptacle is a standard three or five pole electrical connector with shortened leads and terminals added.

The five pole plug has four leads 101,6 mm (4.0) long and one 177,8 mm (7.0) long.

The three pole plug has two leads 101,6 mm (4.0) long and one 177,8 mm (7.0) long.

All of the wires have Underwriters recognized non-solder insulated eyelet

terminals. The #4 and #2 leads are attached to the "A" solenoid, and the #5 and #1 leads are attached to the "B" solenoid. The green wire is used for the ground connection (#8 screw furnished).

Electrical Connector Plug

Millimeters (inches)

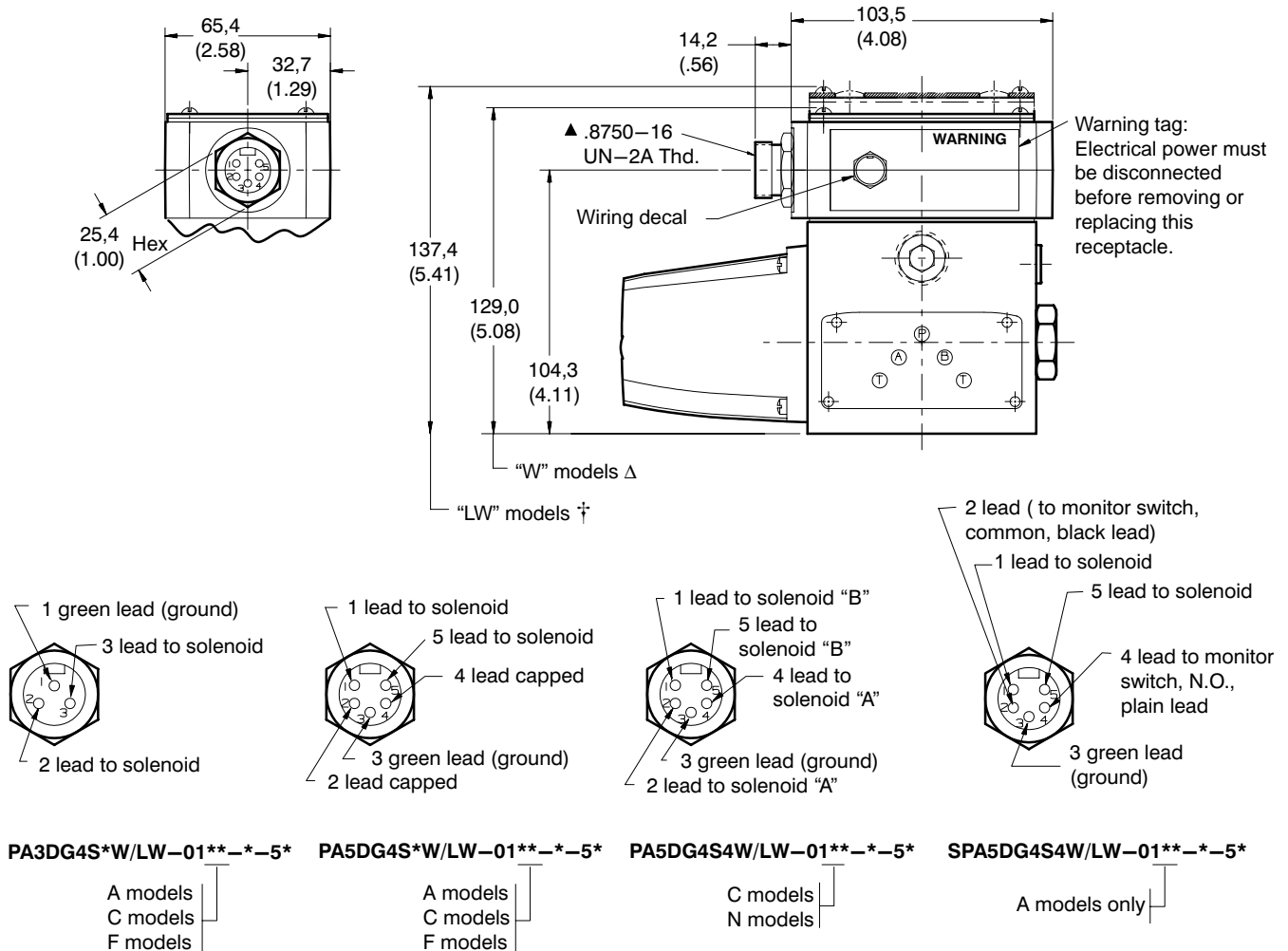

▲ Electrical connection is over solenoid on single solenoid models, and over "b" solenoid on dual solenoid models. See diagram plate for "b" solenoid location.

† Receptacle will be pre-wired directly to the terminals on the solenoid indicator light package. (For exception see note "★").

★ For models with monitor switch, wires to be supplied and connected by customer.

Electrical rating 600 volts, 3 pole, 10 amps and 5 pole, 8 amps. Female portable plug to be furnished by customer.

Δ Receptacle will be prewired to the solenoid eyelets. The connection will be made via No. 6 screws and nuts insulated with black electrical tape. (For exception see note "★").

Application Data

Fluid Cleanliness

Proper fluid condition is essential for long and satisfactory life of hydraulic components and systems. Hydraulic fluid must have the correct balance of cleanliness, materials and additives for protection against wear of components, elevated viscosity and inclusion of air.

Recommendations on contamination control methods and the selection of products to control fluid condition are included in Vickers publication 561, "Vickers Guide to Systemic Contamination Control".

The book also includes information on the Vickers 2 µm, 5 µm and 15 µm. concept of "ProActive Maintenance". The following recommendations are based on ISO cleanliness levels at

For products in this catalog the recommended levels are:
0 to 210 bar (3000 psi) **20/18/15**
210 + bar (3000 + psi) **19/17/14**

Vickers products, as any components, will operate with apparent satisfaction in fluids with higher cleanliness codes than those described. Other manufacturers will often recommend levels above those specified.

Experience has shown, however, that life of any hydraulic components is shortened in fluids with higher cleanliness codes than those listed above. These codes have been proven to provide a long trouble-free service life for the products shown, regardless of the manufacturer.

Flouorocarbon seals are standard and are suitable for use with phosphate ester type fluids or their blends, water glycol, water-in-oil emulsion fluids and petroleum oil. Refer to data sheet 694 for hydraulic fluid and temperature recommendations.